

Objective lenses

Field of view, Instantaneous Field of View, and selection criteria

Objective Lenses for Resonon Imagers enable a wide variety of applications. Variables to consider include distance to the object to be imaged, the size of the object, and the spatial (pixel) resolution desired. Review the technical data, visit our website or contact Resonon for assistance in selecting the proper lens for your application.



Line Scan Imaging

Resonon imagers are line-scan imagers that build an image one row at a time. Each time the imager takes a "snapshot" a row of pixels is captured. To assemble a 2D image, multiple lines or "snapshots" are recorded and assembled line by line into a continuous, streaming 2D image.

Field of View (FOV)

The Field of View (FOV) defines the long dimension of the line "seen" by the imaging spectrometer in units of degrees. (See image.) By changing the objective lens to a Resonon imaging spectrometer, you change the FOV. See the table below to identify the lens that provides the optimal FOV for your application.

Instantaneous Field of View (IFOV)

The Instantaneous Field of View (IFOV) defines the narrow dimension of the line "seen" by the imaging spectrometer. The IFOV is traditionally reported in units of milli-radians. Example calculations, provided below, show how to use the IFOV to determine how much of your object will be seen by each imaged line. See the table below to select the lens that provides the appropriate IFOV for your application.

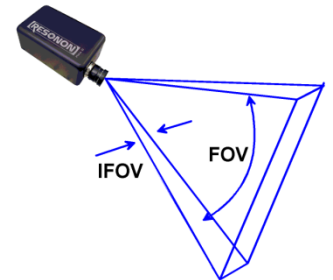

Objective lenses

Resonon Lens Data

Objective Lenses for Pika II

Lens	Resonon part #	Focal Length	FOV (deg) Θ	IFOV (mrad) β
Schneider Tel-Xnar	1000098	70 mm	3.9	0.2
Schneider Xenoplan	1000097	50 mm	5.5	0.3
Schneider Xenoplan	1000096	23 mm	12.0	0.65
Schneider Xenoplan	1000095	17 mm	16.0	0.88
Schneider Cinegon	1000094	12 mm	22.5	1.25
Schneider Cinegon	1000093	8 mm	33.0	1.9
Schneider Cinegon	1000092	6 mm	43.5	2.5

Objective Lenses for Pika XC

Lens	Resonon part #	Focal Length	FOV (deg) Θ	IFOV (mrad) β
Schneider Tel-Xnar	1000098	70 mm	7.2	0.36
Schneider Xenoplan	1000097	50 mm	10.0	0.5
Schneider Xenoplan	1000096	23 mm	21.5	1.1
Schneider Xenoplan	1000095	17 mm	29.0	1.5
Schneider Cinegon	1000094	12 mm	40.0	2.1
Schneider Cinegon	1000093	8 mm	57.5	3.1
Schneider Cinegon	1000092	6 mm	72.0	4.2

Objective Lenses for Pika NIR

Lens	Resonon part #	Focal Length	FOV (deg) Θ	IFOV (mrad) β
Navitar	1000101	50 mm	8.2	0.5
Navitar	1000100	35 mm	11.7	0.71
Navitar	1000099	25 mm	16.3	1.0
Resonon Custom	1000440	3.6 mm	90	6.9

Objective lenses

Lens selection

Lens Selection Example

Lens selection depends on the size of the objects and the details that need to be seen. There are two dimensions to consider. The side-to-side Field of View (FOV) is commonly called the "Across Track" dimension while the narrow Instantaneous Field of View (IFOV) dimension is called the "Along-track" dimension (see figure 1). The length of an object "seen" per pixel of the imager is known as the Ground Sample distance or GSD.

Along-track

For a line-scan imager located a distance H from an object (see image below):

$$\text{Eq. 1 } \textit{Along-track } \text{GSD}_A = (\text{IFOV}_{\text{rad}}) * H \textit{ or } \text{IFOV}_{\text{rad}} = \text{GSD}_A / H \textit{ where IFOV is in units of radians}$$

Across-track

$$\text{Eq. 2 } \textit{Swath} = (2 * H) * \tan_d(\text{FOV}_d / 2) \textit{ where FOV is in units of degrees}$$

$$\text{Eq. 3 } \textit{Cross-track } \text{GSD}_C = \textit{swath} / (\textit{number of cross-track pixels})$$

Example

Using a Pika II mounted 2 meters above the objects, what lens is necessary for a minimum detail or GSD of 3 mm?

Answer - Starting with Eq.1, we want an Along-track GSD_A of 3 mm, our height above the objects is 2m. Solving for IFOV we get: $\text{IFOV} = (3 \text{ mm}) / (2000 \text{ mm}) = 1.5 \text{ mrad}$. Thus, we want a lens with an IFOV of 1.5 mrad or smaller (smaller for higher detail). The lens table shows that a 12 mm objective lens has an IFOV of 1.25 mrad and a FOV of 22.5 degrees. Use Eq.1 to check: $\text{Along-track } \text{GSD}_A = (0.00125) * (2000 \text{ mm}) = 2.5 \text{ mm}$. Next, check the Across-track dimensions: $\text{swath} = (2 * 2000 \text{ mm}) * \tan(22.5/2) = 796 \text{ mm}$. The Pika II has 640 cross-track channels, so using Eq.3: $\text{Cross-track } \text{GSD} = (796 \text{ mm}) / 640 = 1.24 \text{ mm}$. Thus both the Along-track and Cross-track GSDs are less than 3 mm.

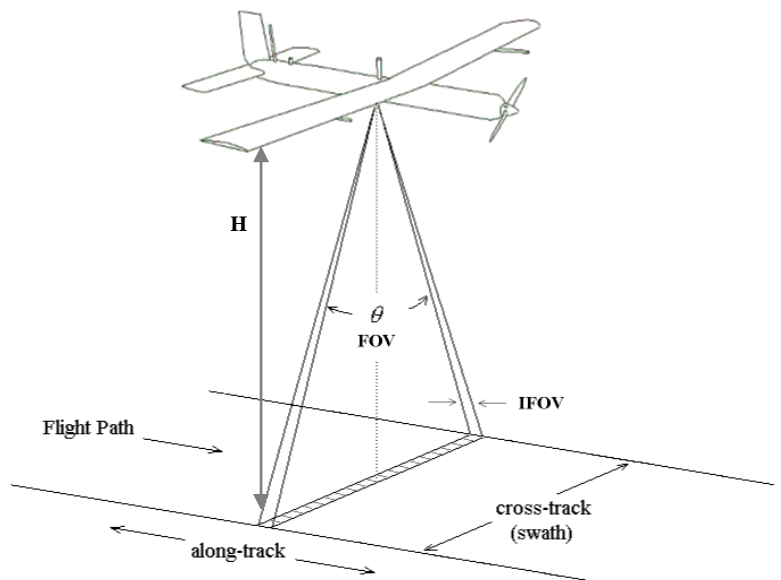

Contact

RESONON

Resonon Hq

619 N. Church #3
Bozeman, MT 59715, USA
+1.406.586.3356

Resonon East

649 Massachusetts Ave. #7
Cambridge, MA 02139, USA
+1.406.586.3356

Online

inquiry@resonon.com
<http://www.resonon.com>